

EST . 1958

RESIGLAS Storage



non-contractual pictures

Our fibreglass grease trap will contribute to the protection of our environment and your absorption pit. Compared to concrete, they are very competitive. Their ease of installation saves time on site. Installed close to the kitchen, this grease trap is designed to retain solids, grease and oil contained in waste water coming from the kitchen. Larger solids are retained in the perforated basket and smaller solids settle at the bottom to form the sludge. The lighter grease and oil solidify and move up to float at the water surface and are trapped inside as they cannot exit due to the siphonic type outlet.

Maintenance

- For the smooth running, the grease trap should be cleaned frequently.
- Regular Skimming of solid grease on water surface
- Regular cleaning of the perforated basket
- Removal of sludge at the bottom of the container – Approximately once every four months
- Fill up the container with clean water after completing all the above

FIBREGLASS GREASETRAP

140 LTS Model A

Working Capacity: 140 Lts
Total Capacity: 200 Lts
Height: 520 mm
Width: 570 mm
Length: 1010 mm

MADE IN MAURITIUS

For more info, visit us online...

RESIGLAS *Storage*

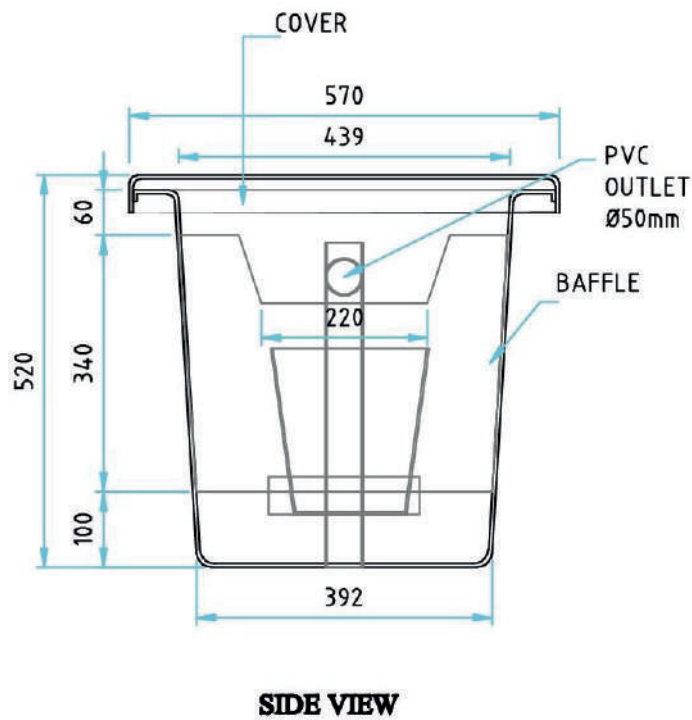
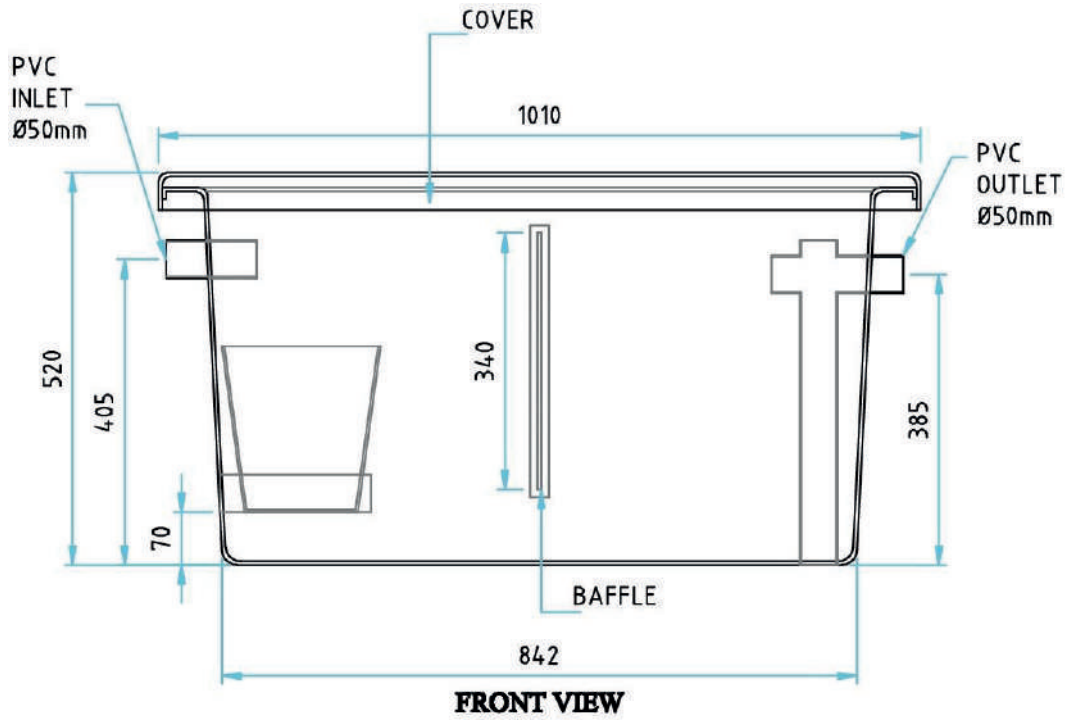

SCALE: 1/10

RESIGLAS Storage

INSTALLATION INSTRUCTIONS

FIBREGLASS GREASE TRAP

140 | 200 | 500 | 1000 | 2500 | 3500 | 5500

CAUTION

- Special care should be taken during piping connection of the grease trap.
INLET (IN): Piping from kitchen (sink and dish washer)
OUTLET (OUT): Piping to an all waste water Grease trap or directly to the absorption pit.
- The piping should have a slope of 2% minimum.
- The grease trap should not be installed in driveways and areas where heavy load may occur.
- The grease trap should be installed in a horizontal position, level and close to the kitchen.

INSTALLATION PROCEDURE

- 1 This grease trap is generally installed underground. Therefore a hole will have to be dug. For dimensions refer to column A in the table below. The height of the excavation will depend on the topography of the land and the piping to the grease trap. Note that the minimum slope for the inlet piping is 2% so as to avoid clogging of piping. Therefore it is recommended to install your grease trap in the lowest part the plot. This grease trap may be completely buried, except for the cover or semi-buried or at ground level, but be careful of the inlet piping which have a minimum slope of 2%.
- 2 The grease trap is to be installed on a 'rock sand' bed of 110mm thick. The bed should be LEVELLED and COMPACTED (therefore an additional 100mm should be taken into consideration when digging the grease trap hole).
- 3 Position the grease trap on the 'rock sand' bed leaving equal distances between the grease trap and the wall face of the hole. Check that the grease trap is LEVEL.
- 4 Fill up the grease trap with water until it overflows through the outlet (OUT). This should be done before piping of inlet and outlet, to avoid possible stress or cracks of piping, if the grease trap sinks slightly on its 'rock sand' bed when fully loaded.
- 5 Backfill remaining spaces between the grease trap and the wall faces of the hole up to 100mm underneath the outlet (OUT) and inlet (IN) with sand or rock sand.
WARNING – No rocks and debris
- 6 PIPING CONNECTION
Inlet (IN) – piping from kitchen (sinks and dish washer)
Outlet (OUT) – piping to an all waste water septic tank, or directly to the absorption pit.
- 7 Complete the backfilling of the spaces with more sand or rock sand and soil as required. Do not use rocks and debris.
- 8 The outlet (OUT) of the grease trap is to be connected directly to an absorption pit or via a all waste water septic tank. The latter should be at a distance of not less than 1m50 from the septic tank. The height of the absorption pit should be of a minimum of (refer to column B in table), measured as from the level of the inlet (IN) of the grease trap, and a diameter of (refer to column B in table). Fill up the absorption pit with rocks up to 50mm above the outlet piping. Complete the absorption pit with macadam 50mm, rock sand (coarse) 25mm, plastic or geotextile material and then soil as required.

RESIGLAS

Storage

Model/Ref	Hole Dimension (A)	Absorption Pit Dimensions (B)
Polyethylene 75	1m00 (Dia)	1m00 (H) x 1m50 (Dia)
Fibreglass A - 140	1m20 (L) x 0m70 (W)	1m00 (H) x 1m50 (Dia)
Fibreglass B - 200	1m10 (Dia)	1m00 (H) x 1m50 (Dia)
Fibreglass C - 500	1m50 (L) x 1m20 (W)	1m20 (H) x 1m50 (Dia)
Fibreglass C - 1000	2m50 (L) x 1m20 (W)	1m30 (H) x 1m50 (Dia)
Fibreglass D - 1800	2m90 (L) x 1m20 (W)	1m50 (H) x 1m30 (Dia)
Fibreglass D - 2500	3m00 (L) x 1m40 (W)	2m00 (H) x 1m50 (Dia)
Fibreglass D - 3500	3m80 (L) x 1m60 (W)	2m00 (H) x 1m60 (Dia)
Fibreglass D - 5500	4m50 (L) x 1m80 (W)	2m00 (H) x 1m80 (Dia)