

EST . 1958

RESIGLAS *Storage*



non-contractual pictures

This septic tank is designed to receive and liquefy solids contained in WC waste water (toilets and urinals) due to an appropriate internal set up. RAIN WATER AND HOUSEHOLD WASTE WATER (kitchen sink, bathroom, washing machine) SHOULD NOT BE ALLOWED.

Specifications

- Working Capacity : 3125 Lts
- Total Capacity : 3800 Lts
- Overall Dimensions :
1910 mm (Dia) x 1760 mm (H)
- Compartments : 2 (2 Manholes)
- Users : 5 persons (Toilets and household Waste Water) / 17 persons (Toilets waste water only)
- Inlet (in) and Outlet (out) : P.V.C 110mm (Dia)
- Weight : 185 Kg (Incl. cover)
- Colour : White externally and Grey internally

FIBREGLASS TANKS

SEPTIC 3.1 Model B

MADE IN MAURITIUS

For more info, visit us online...

RESIGLAS *Storage*

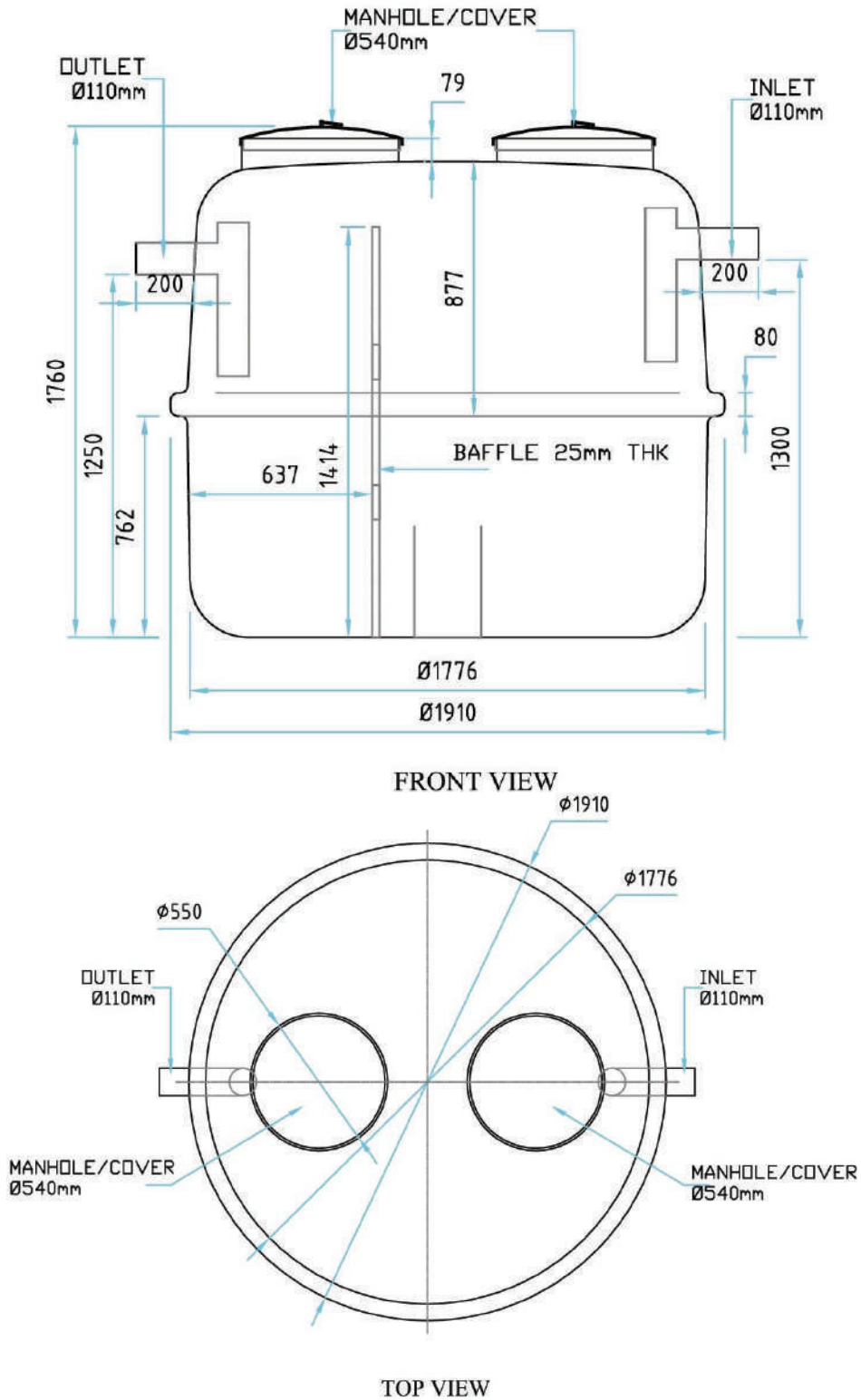

SCALE: 1/25

RESIGLAS Storage

INSTALLATION INSTRUCTIONS FIBREGLASS SEPTIC TANKS

1.8A | 2.5A | 3.1B | 5.4B

CAUTION

No chemicals should be allowed in a septic tank. However cleaning agents, biodegradable detergents and aseptic products designed for toilet may be used in reasonable quantity.

- Special care should be taken during piping connection of the septic tank.

- INLET (IN): Piping from house

OUTLET (OUT): Piping to the absorption pit.

- The piping should have a slope of 2% minimum.
- - The incoming piping should be fitted with an air vent pipe (above roof), minimum diameter 75mm.
- - The septic tank should not be installed in flooded areas / high water table, driveways and areas where heavy load may occur. Unless it is protected by a heavy duty reinforced concrete slab which is NOT supported by the septic tank.
- Note: Access manholes needs to be put in place by the "Customer" on concrete slab for emptying purposes & maintenance.
 - Whenever a septic tank needs to be emptied for maintenance, it should be refilled with water immediately, so as to avoid risk of collapse of the septic tank due to external pressures (soil and or high water table).
 - The septic tank should be installed in a horizontal position and level.

INSTALLATION PROCEDURE

- 1 This septic tank is generally installed underground. Therefore a hole will have to be dug. The height of the excavation will depend on the topography of the land and the piping to the septic tank. Note that the minimum slope for the inlet piping is 2% so as to avoid clogging of piping. Therefore it is recommended to install your septic tank in the lowest part of the plot. This septic tank may be completely buried (including the manhole cover) or, semi-buried or, at ground level, but be careful of the inlet piping which have a minimum slope of 2%. For semi-buried and ground level installation the cover will have to be sealed with silicon, to avoid bad odours.
- 2 The septic tank should NOT be buried more than 400mm below ground level. In case a riser is used on the manhole, this measurement should be taken on the septic tank and NOT on the manhole cover of the riser.
If the septic tank is to be buried more than 400mm below ground level, it must be protected by a heavy duty reinforced concrete slab, which is NOT supported by the septic tank.
- 3 The septic tank is to be installed on a 'rock sand' bed of 200mm thick. The bed should be LEVELLED and COMPACTED (therefore an additional 200mm should be taken into consideration when digging the septic tank hole).
- 4 Position the septic tank on the 'rock sand' bed leaving equal distances between the septic tank and the wall face of the hole. Check that the septic tank is LEVEL.
- 5 Fill up the septic tank with water until it overflows through the outlet (OUT). This should be done before piping of inlet and outlet, to avoid possible stress or cracks of piping, if the septic tank sinks slightly on its 'rock sand' bed when fully loaded.
- 6 Backfill remaining spaces between the septic tank and the wall faces of the hole up to 100mm underneath the outlet (OUT) and inlet (IN) with sand or rock sand.
WARNING – No rocks and debris
- 7 PIPING CONNECTION (PVC 110mm Dia)
Inlet (IN) – piping from toilets and urinals.
Outlet (OUT) – piping to the absorption pit.
- 8 Complete the backfilling of the spaces with more sand or rock sand and soil as required. Do not use rocks and debris.
- 9 The outlet (OUT) of the septic tank is to be connected directly to an absorption pit. The latter should be at a distance of not less than 2m50 from the septic tank. The height of the absorption pit should be of a minimum of (refer to column B in table below), measured as from the level of the inlet (IN) of the septic tank, and a diameter of (refer to column B in table below). Fill up the absorption pit with rocks up to 200mm above the outlet piping. Complete the absorption pit with macadam 150mm, rock sand (coarse) 100mm, plastic or geotextile material and then soil as required.

EST . 1958

RESIGLAS Storage

Model/Ref (m ³)	Hole Dimension (A)	Absorption Pit Dimensions (B)
Fibreglass A-1.8	2m90 (L) x 1m20 (W)	1m50 (H) x 1m30 (Dia)
Fibreglass A-2.5	3m00 (L) x 1m40 (W)	2m00 (H) x 1m50 (Dia)
Fibreglass B-3.1	2m40 (Dia)	2m00 (H) x 1m50 (Dia)
Fibreglass B-5.4	2m90 (Dia)	2m00 (H) x 1m75 (Dia)